

T E L E S C O P I C B O O M S

H 14 TX H 16 TPX



- 34 ft 9 in (10.6 m) and 40 ft 4 in (12.3 m) horizontal outreach.
- Max. load capacity: 230 kg (507 lb).
- Standard 4 wheel drive.
- 14 in (35 cm) ground clearance.

ISO 9001
GROUP
PINGUELY
HAULOTTE



ARTICULATED BOOMS



VERTICAL MASTS



TELESCOPIC BOOMS



SCISSOR LIFTS



TRAILERS

Haulotte®

ON THE UP

H 14 TX H 16 TPX

Telescopic booms

The Haulotte® advantages

- Hydraulic differential lock, standard 4 wheel drive, 15 in (35 cm) ground clearance improve rough terrain capability
- H 16 TPX : improved working area through a positive / negative articulating fly jib with 140° movement (-70° / +70°)
- Continuous 360° turntable rotation
- 180° hydraulic platform rotation
- Compact travel/transport dimensions
- Full proportional controls and simultaneous boom functions improve productivity
- Robust, reliable and easy to maintain design

STANDARD FEATURES

- Deutz diesel engine
- 4 wheel drive and 2 front steering wheels
- 5° tilt alarm
- 12 V electrical control system
- 12 V – 95 Ah – 450 A battery
- Free wheeling device
- Load limiter in cage
- Battery electric emergency control in cage
- Hourmeter
- Slewing block pin
- Towing hooks / lifting eyes
- 2 hooks for safety harnesses in platform
- Horn

OPTIONS & ACCESSORIES

- H 16 TPX: large platform: 7 ft 6 in x 2 ft 7 in (2.3 m x 0.8 m)
- Power line to cage
- Rotating beacon
- Working light
- Motion alarm
- Encoded starting device
- Biodegradable oil
- Catalytic exhaust
- Dual gas/fuel engine
- On-board generator 3 kw
- Hot weather kit
- Cold weather kit

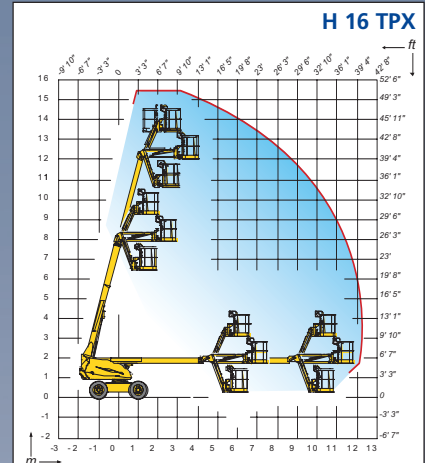
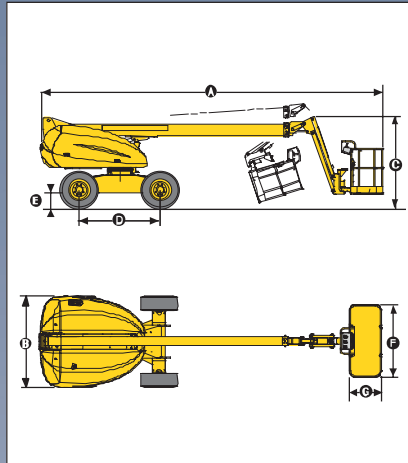

SPECIFICATIONS

	H 14 TX		H 16 TPX	
Working height	14.07 m	46 ft 1 in	15.44 m	50 ft 8 in
Platform height	12.07 m	39 ft 7 in	13.44 m	44 ft 1 in
Horizontal outreach	10.6 m	34 ft 9 in	12.3 m	40 ft 4 in
Platform capacity	230 kg	507 lb	230 kg	507 lb
Fly jib range of motion	n/a	n/a	140° (-70° / +70°)	
Jib length	n/a	n/a	1.5 m	59 in
A Length	7.60 m	24 ft 11 in	8.42 m	27 ft 8 in
B Width	2.3 m	7 ft 6 in	2.3 m	7 ft 6 in
C Stowed height	2.21 m	7 ft 3 in	2.21 m	7 ft 3 in
D Wheelbase	2 m	6 ft 6 in	2 m	6 ft 6 in
E Ground clearance	35 cm	14 in	35 cm	14 in
F x G Platform size	2.3 m x 0.8 m	91 in x 32 in	1.8 m x 0.8 m	71 in x 32 in
Travel/transport length	7.60 m	24 ft 11 in	6.71 m	22 ft
Travel/transport height	2.21 m	7 ft 3 in	2.50 m	8 ft 2 in
Tailswing	0.8 m	32 in	0.8 m	32 in
Drive speed	6 km/h	3.7 mph	6 km/h	3.7 mph
Outside turning radius (wheel)	4.80 m	15 ft 9 in	4.80 m	15 ft 9 in
Turntable rotation – continuous	360°	360°	360°	360°
Hydraulic platform rotation	180°	180°	180°	180°
Engine	Diesel Deutz F 3L 1011 F - 28 kW - 38CV			
Controls	Proportional		Proportional	
Gradeability	50%		50%	
Tyres (Foam Filled)	Sks Hauler - 14 - 17.5		Sks Hauler - 14 - 17.5	
Hydraulic tank	150 l	33 gallons	150 l	33 gallons
Fuel tank	150 l	33 gallons	150 l	33 gallons
Weight	6040 kg	13,315 lb	6600 kg	14,551 lb



D I S T R I B U T E D B Y

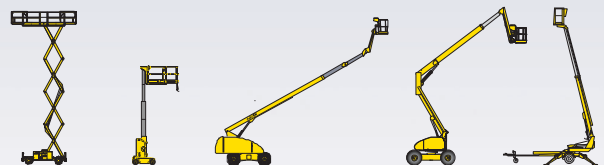

Haulotte®

HAULOTTE UK LTD • Stafford Park 6 - Telford - Shropshire TF3 3AT - UK • Tel : +44 (0)1952 292753 • Fax : +44 (0)1952 292758 • e-mail: haulotte@haulotte.co.uk
 HAULOTTE SCANDINAVIA AB • Aröds Industriväg 66B - 44243 Hisingsbacka - SWEDEN • Tel : +46 (0) 31 744 32 90 • Fax : +46 (0) 31 744 32 99 • e-mail: hwallin@haulotte.se
 HAULOTTE AUSTRALIA PTY LTD • 39 Nicholas Drive - Dandenong - VIC - 3175 - AUSTRALIA • Tel : +61 (0)3 9706 6787 • Fax : +61 (0)3 9706 6797 • e-mail: sales@haulotte.com.au
 PINGUELY-HAULOTTE GROUP • La Péronnière - B.P. 9 - 42152 L'Homme - FRANCE • Tél : +33 (0) 4 77 29 24 24 • Fax : +33 (0) 4 77 29 43 95 • e-mail: haulotte@haulotte.com
 Web : http://www.haulotte.com