

OPTIMUM 6/8

Electric
scissor lifts



- Stowed height 1.91 m (6ft 3in), width 0.76 m (2ft 5in).
- Platform capacity 280 kg (617 lb) (Optimum 6).
- Security system with Pot Hole protection.



ISO 9001
GROUP
PINGUELY
HAULOTTE



ARTICULATED BOOMS



VERTICAL MASTS



TELESCOPIC BOOMS



SCISSOR LIFTS



TRAILERS

Haulotte®

ON THE UP

OPTIMUM 6/8

The Haulotte® advantages

- Compact : stowed height for easy travel through standard "doorways"
- Length : 1.83 (6ft) and width 0.76 m (2ft 5in) allow operation in the most congested areas
- Outside turning radius 1.70 m (5ft 6in) ensures excellent manoeuvrability
- 8 cm (3in) ground clearance allows for both inside and outside uses
- Pot Hole protection ensures maximum safety
- High operating autonomy
- Robust reliable and easy to maintain design

STANDARD FEATURES

- Non marking tyres
- 0,92 m (3ft) platform extension
- 2° tilt alarm
- 2 drive speed
- 2 wheel drive and steer
- Free weeling device
- 24 V - 4x6 V - 180 Ah batteries
- 30 Amp battery charger
- Battery charge indicator
- Hour meter
- Towing hooks / lifting eyes
- Emergency lowering system

OPTIONS & ACCESSORIES

- Motion alarm
- 220 V power to platform
- Flashing light
- Working light



ELECTRIC SCISSOR LIFTS

OPTIMUM 8

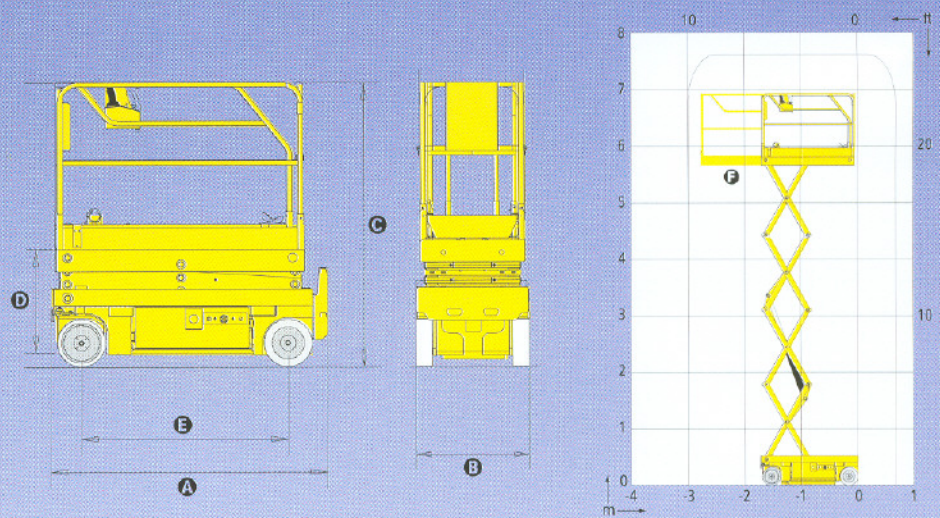

SPECIFICATIONS

	OPTIMUM 6		OPTIMUM 8	
Working height	6,45 m	20 ft 7 in	7,6 m	24 ft 11 in
Platform height	4,45 m	14 ft 7 in	5,76 m	18 ft 11 in
Driveable at full height	6,45 m	21 ft 2 in	7,6 m	25 ft
Platform capacity	280 kg	617 lb	230 kg	507 lb
A Stowed length	1,73 m	5ft 8 in	1,73 m	5 ft 8 in
With access steps	1,88 m	6 ft	1,88 m	6 ft
B Width	0,76 m	2 ft 6 in	0,76 m	2 ft 6 in
C Stowed height (guardrails)	1,91 m	6 ft 3 in	2,0 m	6 ft 7 in
D Stowed height (platform)	0,80 m	2 ft 7 in	0,89 m	3 ft
E Wheelbase	1,38 m	4 ft 6 in	1,38 m	4 ft 6 in
Platform size	1,65 x 0,7 m	65 in x 28 in	1,65 x 0,7 m	65 in x 28 in
F Extension : Size	0,92 m	3 ft	0,92 m	3 ft
Ground clearance	8 cm	3 in	8 cm	3 in
With deployed Pot Hole	2,2 cm	0.9 in	2,2 cm	0.9 in
Drive speed	0,6 - 4,55 km/h	0.37 - 2.83 mph	0,6 - 4,55 km/h	0.37 - 2.83 mph
Outside turning radius	1,70 m	5 ft 7 in	1,70 m	5 ft 7 in
Lift / lower (sec.)	25/18		30/23	
Gradeability	25%			
Tilt alarm	2°			
controls	Proportional			
Batteries	180 Amp/h			
Tyres (solid / non marking)	Caoutchouc solid Dia 317			
Hydraulic tank	18 l / 4 gal			
Weight	1 350 kg	3.000 lb	1 450 kg	3.200 lb

AS1418.10



Haulotte®